



Physics by fiziks

Learn Physics in Right Way



Physics by fiziks

JEST Physics

Question Paper -2021

Learn Physics in Right Way

Be Part of Disciplined Learning

(PAPER CODE-D)

Part-A: 1-Mark Questions

- Q1. A negative logic is the one in which the 0's and the 1's in the truth tables are interchanged. In such a negative logic, the normal NAND gate would behave like a
- (a) NOR gate (b) AND gate
(c) OR gate (d) NAND gate
- Q2. The six faces of a cube are painted violet, blue, red, green, yellow and orange. If the cube is rolled 4 times, what is the probability that the green face appears exactly 3 times?
- (a) $\frac{3}{24}$ (b) $\frac{5}{124}$ (c) $\frac{5}{324}$ (d) $\frac{15}{222}$
- Q3. A particle with energy E is in a bound state of the one-dimensional Hamiltonian $H = -\frac{\hbar^2}{2m} \frac{d^2}{dx^2} + V(x)$. The expectation value of the momentum $\langle p \rangle$
- (a) is always zero
(b) depends on the degeneracy of the eigenstate
(c) is zero if and only if the potential symmetric $V(-x) = V(x)$
(d) depends on the energy E of the eigenstate
- Q4. A glass of radius R and refractive index n acts like a lens with focal length
- (a) $-\frac{nR}{2(n-1)}$ (b) $+\frac{nR}{2(n-1)}$
(c) $-\frac{nR}{2(n-1)^2}$ (d) $+\frac{nR}{2(n-1)^2}$
- Q5. An ideal op-amp and a silicon transistor T are used in the following circuit. Find the output voltage V_{out}

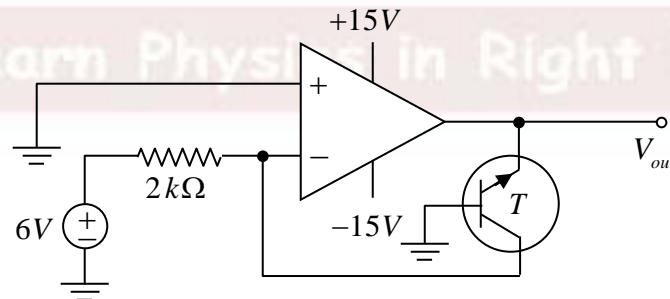

- (a) +5.3 V (b) -0.7 V (c) +0.7 V (d) -15 V

Q6. A spaceship moves away from Earth with a relativistic speed v and fires a shuttle craft in the forward direction at a speed v relative to the spaceship. The pilot of the shuttle craft launches a probe in the forward direction at a speed v relative to the Earth? What will be the speed of the probe relative to the Earth?

- (a) $3v$ (b) $\frac{3v}{\sqrt{1-\frac{v^2}{c^2}}}$
 (c) $\left(\frac{3+v^2/c^2}{1+3v^2/c^2}\right)v$ (d) $\frac{2v}{1+v^2/c^2} + v$

Q7. Let ABCDEF be a regular hexagon. The vector $\vec{AB} + \vec{AC} + \vec{AD} + \vec{AE} + \vec{AF}$ will be

- (a) 0 (b) \vec{AD} (c) $2\vec{AD}$ (d) $3\vec{AD}$

Q8. An ideal gas at temperature T is composed of particles of mass m , with the x -component of velocity v_x . The average value of $|v_x|$ is

- (a) 0 (b) $\sqrt{3k_B T / m}$ (c) $\sqrt{k_B T / 2\pi m}$ (d) $\sqrt{2k_B T / \pi m}$

Q9. A particle of mass m is subject to the potential $V(x, y, t) = K(x^2 + y^2)$, where (x, y) are the cartesian coordinates of the particle and K is a constant. Which one of the following quantities is a constant of motion?

- (a) $\dot{y}x + \dot{x}y$ (b) $\dot{y}x - \dot{x}y$ (c) $\dot{y} + \dot{x}$ (d) $\dot{y}y + \dot{x}x$

Q10. What value the following infinite series will converge to?

$$\sum_{n=1}^{\infty} \frac{n^2}{2^n}$$

- (a) $\frac{\pi^2}{6}$ (b) $\frac{1}{2}$ (c) 3 (d) 6

Q11. If \vec{L} is the angular momentum operator in quantum mechanics, the value of $\vec{L} \times \vec{L}$ will be

- (a) 0 (b) $i\hbar\vec{L}$ (c) $|\vec{L}|$ (d) $\hbar\vec{L}$

Q12. In an open circuited p-n junction diode, the barrier voltage at the junction is generated due to

- (a) Minority carriers in the p and n sides
 (b) Majority carriers in the p and n sides
 (c) Immobile negative charge in the p-side and positive charge in the n-side
 (d) Immobile positive charge in the p-side and negative charge in the n-side

Q13. The smallest dimension of the Hilbert space in which we can find operators \hat{x}, \hat{p} that satisfy $[\hat{x}, \hat{p}] = i\hbar$ is

- (a) 1 (b) 3 (c) 4 (d) ∞

Q14. Consider a system consisting of three non-degenerate energy levels, with energies $0, \epsilon$ and 2ϵ . In the limit of infinite temperature $T \rightarrow \infty$, the probability of finding a particle in the ground state is

- (a) 0 (b) $1/2$ (c) $1/3$ (d) 1

Q15. In the figure below with ideal op-amps, the value of $R = 10k\Omega$, $V_1 = -10mV$, and $V_2 = -30mV$. Calculate V_{out} .

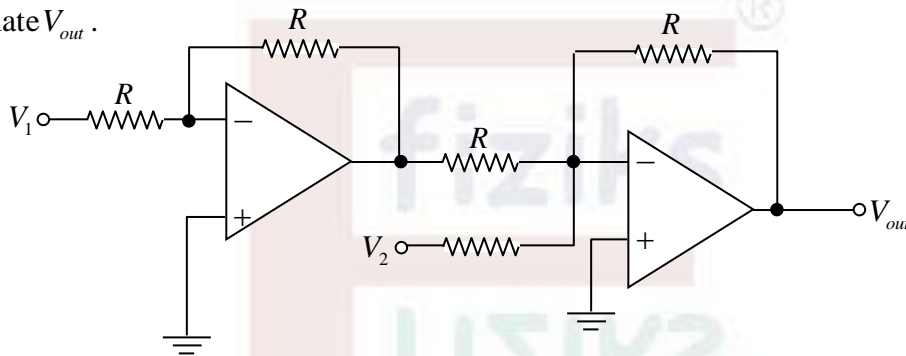

- (a) $+40mV$ (b) $-40mV$ (c) $+20mV$ (d) $-20mV$

Q16. A flat soap film has a uniform thickness of 510 nm. White light (having wavelengths in the range of about 390 – 700 nm) is incident normally on the film. If the refractive index of the soap is 1.33, what will be the dominant colour of the reflected light?

- (a) Violet (b) Green (c) Red (d) White

Q17. A particle of mass m having a non-zero angular momentum of magnitude l is subject to a central force potential $V(\vec{r}) = k \ln(r)$, where k is a constant and $r = |\vec{r}|$. What is the radius R at which it will have a circular orbit? Will the circular orbit be stable or unstable?

- (a) $R = \frac{l}{\sqrt{2km}}$, unstable orbit (b) $R = \frac{l}{\sqrt{2km}}$, stable orbit
(c) $R = \frac{l}{\sqrt{km}}$, unstable orbit (d) $R = \frac{l}{\sqrt{km}}$, stable orbit

Q18. Positronium is a short lived bound state of an electron and a positron. The energy difference between the first excited state and ground state of positronium is expected to be around

- (a) four times that of the Hydrogen atom
(b) twice that of the Hydrogen atom
(c) half that of the Hydrogen atom
(d) the same as that of the Hydrogen atom

Q19. A solid sphere and a solid cylinder, both of uniform mass density, start rolling down without slipping from rest from the same height along an inclined plane (see figure). Which one of the following statements is correct?

- (a) The sphere would reach the bottom faster.
- (b) The cylinder would reach the bottom faster.
- (c) The heavier one would reach the bottom faster if both have identical radii.
- (d) Both the objects would reach the bottom at the same time if their radii are identical.

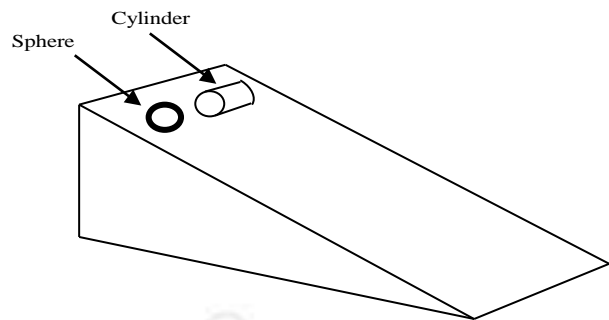

Q20. A one-dimensional box contains three identical particles in the ground state of the system. Find the ratio of total energies of these particles if they were spin- $\frac{1}{2}$ fermions, to that if they were bosons.

- (a) 1
- (b) $\frac{14}{3}$
- (c) 2
- (d) $\frac{1}{3}$

Q21. A monochromatic linearly polarized light with electromagnetic field $\vec{E} = E_0 \sin(\omega t - kz)(\hat{x} + \hat{y})$ is incident normally on a birefringent calcite crystal. The wavelength of the wave is 590 nm and the refractive indices of the crystal along the x -directions and y -directions are 1.66 and 1.49, respectively. If the thickness of the crystal is 434 nm , what will be the polarization of the light that emerges from the crystal?

- (a) Linearly polarized along the same axis as the incident light
- (b) Linearly polarized but along a different axis than the incident light
- (c) Circularly polarized
- (d) Neither linearly nor circularly polarized but elliptically polarized

Q22. Consider the matrix $A = \begin{pmatrix} 1 & 0 & 0 & 1 \\ 0 & -2 & 0 & 0 \\ 0 & 0 & -3 & 0 \\ 1 & 0 & 0 & 4 \end{pmatrix}$

What is the determinant of the matrix $\exp(A)$?

- (a) 1
- (b) $\exp(24)$
- (c) 24
- (d) 0

Part-B: 3-Mark Questions

Q1. Consider a sphere of radius R containing a charge with volume density $\rho(r) = 4\pi\epsilon_0 \alpha/r$. The charge is zero outside the sphere. The electromagnetic potentials (ϕ and \vec{A}) inside the sphere may be written in many ways. Which of the following values of ϕ and \vec{A} inside the sphere describe the situation correctly?

- (a) $\phi = 0, \vec{A} = -2\pi\alpha t \hat{r}$ (b) $\phi = 2\pi\alpha r, \vec{A} = 0$
 (c) $\phi = 0, \vec{A} = -\pi\alpha t \hat{r}$ (d) $\phi = \pi\alpha r, \vec{A} = 0$

Q2. A hollow sphere of radius R , with a small hole at the bottom, is completely filled with a liquid of uniform density (see figure). The liquid drains out of the sphere through the hole at a uniform rate in time T . Which one of the following graphs (a, b, c, d) qualitatively represents the height h of the center of mass (of sphere + liquid inside it), measured from the bottom of the sphere with time?

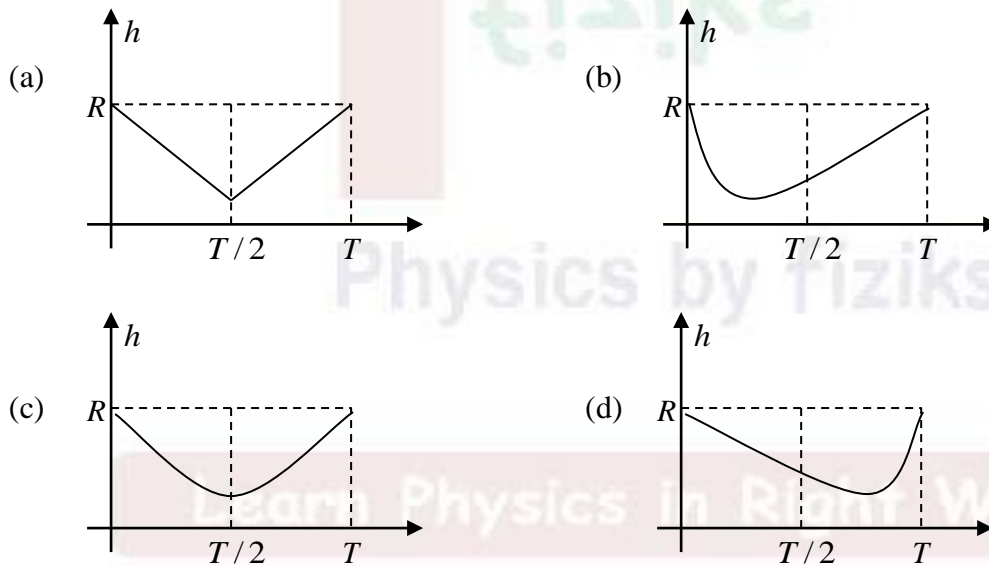
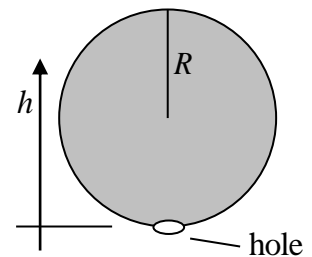

- Q3. An ideal polariser is placed in between two crossed polarisers in a coaxial geometry as shown. The middle polariser is rotated at the angular speed of ω about the common axis. If unpolarized light of intensity I_0 is incident on this system, the emergent intensity of the light would be

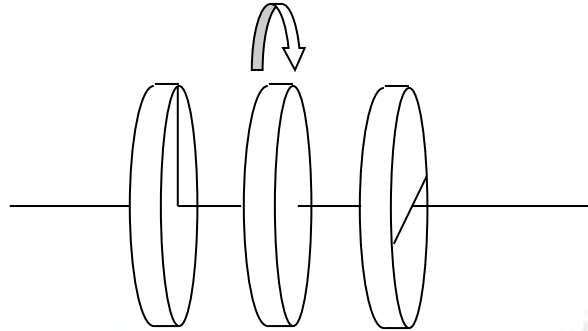

- (a) $\frac{I_0}{8}[1 - \cos 4\omega t]$ (b) $\frac{I_0}{16}[1 - \cos 4\omega t]$
 (c) $\frac{I_0}{16}[1 - \cos \omega t]$ (d) $\frac{I_0}{16}\left[1 - \frac{1}{2}\cos \omega t\right]$
- Q4. An astrophysical observation measured the mass of a star as $(12.41 \pm 1.12)M_\odot$, where M_\odot is the mass of the Sun. Another independent observation measured the mass of the same star as $(8.40 \pm \Delta)M_\odot$. Assuming the errors to have Gaussian distributions, one concluded that the two measurements differed by 3 standard deviations. The value of Δ was approximately
 (a) 0.22 (b) 0.73 (c) 1.04 (d) 1.55
- Q5. Consider the normalized wave function $\psi = a\psi_0 + b\psi_1$ for a one-dimensional simple harmonic oscillator at some time, where ψ_0 and ψ_1 are the normalized ground state and the first excited state respectively, and a, b are real numbers. For what values of a and b , the magnitude of expectation value of x , i.e. $|\langle x \rangle|$, is maximum?
 (a) $a = -b = 1/\sqrt{2}$ (b) $a = b = 1/\sqrt{2}$
 (c) $a = 1, b = 0$ (d) $a = 0, b = 1$
- Q6. M grams of water at temperature T_a is adiabatically mixed with an equal mass of water at temperature T_b , keeping the pressure constant. Find the change in entropy of the system (specific heat of water is C_p).

- (a) $\Delta S = MC_p \ln \left[1 - \frac{(T_a - T_b)^2}{4T_a T_b} \right]$ (b) $\Delta S = MC_p \ln \left[1 + \frac{(T_a + T_b)^2}{4T_a T_b} \right]$
 (c) $\Delta S = MC_p \ln \left[1 + \frac{(T_a - T_b)^2}{4T_a T_b} \right]$ (d) $\Delta S = MC_p \ln \left[\frac{T_a + T_b}{(4T_a T_b)^{1/2}} \right]$

Q7. The circuit given in the figure below is composed of ideal diodes and resistances R . The input waveform is shown on the left.

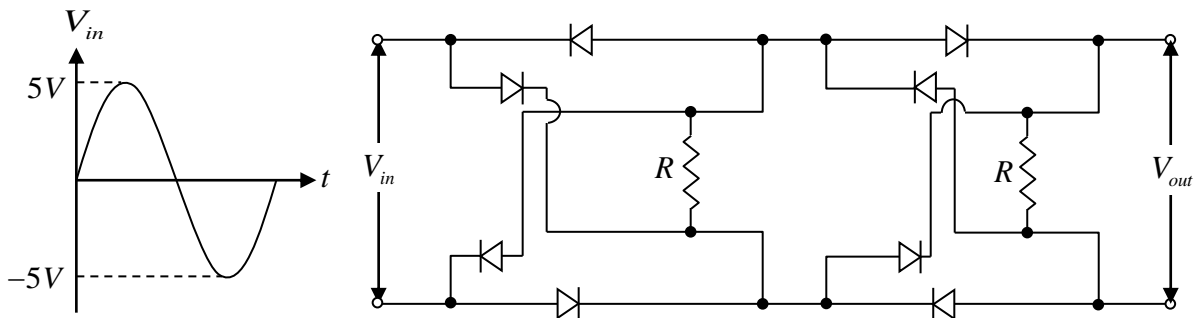

The output waveform would be

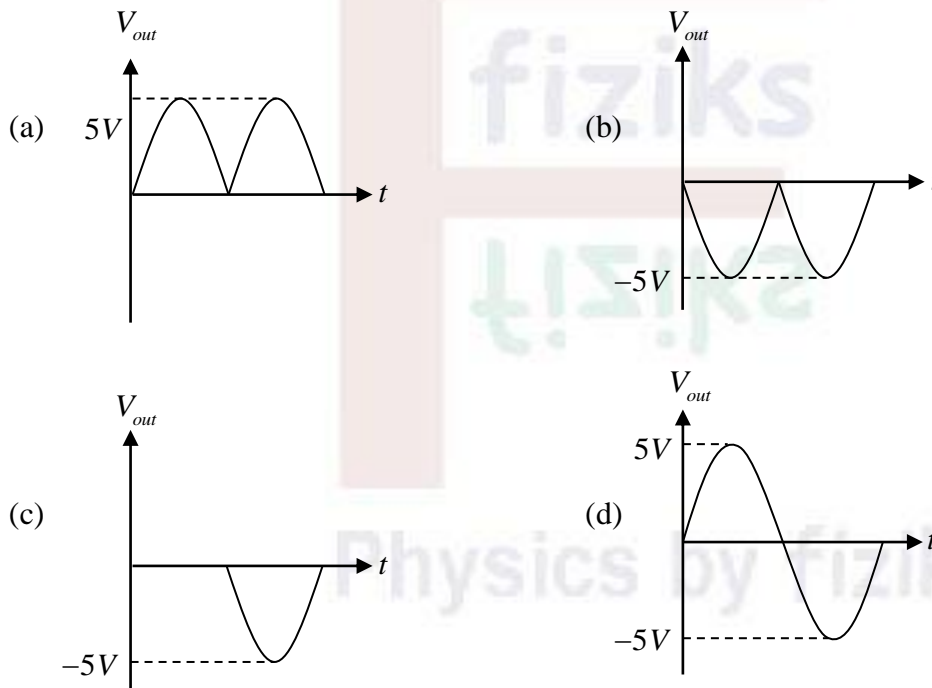

Q8. Consider a 4-dimensional vector space V that is a direct product of two 2-dimensional vector spaces V_1 and V_2 . A linear transformation H acting on V is specified by the direct product of linear transformations H_1 and H_2 acting on V_1 and V_2 , respectively. In a particular basis,

$$H_1 = \begin{pmatrix} 3 & 0 \\ 0 & 2 \end{pmatrix}, \quad H_2 = \begin{pmatrix} 2 & 1 \\ 1 & 1 \end{pmatrix}$$

What is the lowest eigenvalue of H ?

- (a) 1 (b) $\frac{3}{2}$ (c) $3 - \sqrt{5}$ (d) $\frac{1}{2}(3 - \sqrt{5})$

- Q9. Consider a spherical shell of radius R having a uniform surface charge density σ . Suppose we construct a spherical Gaussian surface having the same radius R but its centre shifted from the charged sphere by a distance R (see the figure). What is the total electric flux $\oint \vec{E} \cdot d\vec{A}$ through the Gaussian surface?

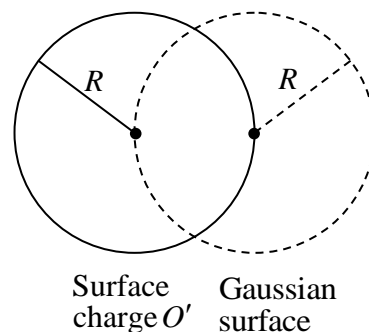

- (a) 0 (b) $\pi R^2 \sigma$ (c) $2\pi R^2 \sigma$ (d) $4\pi R^2 \sigma$
- Q10. A large box, of volume V is fitted with a vertical glass tube of cross-sectional area A , in which a metal ball of mass m fits exactly. The box contains an ideal gas at a pressure slightly higher than atmospheric pressure P because of the weight of the ball. If the ball is displaced slightly from equilibrium, find the angular frequency ω of simple harmonic oscillations. Assume adiabatic behaviour, with ratio of specific heats $\gamma = C_p / C_v$.

(a) $\omega = \sqrt{\frac{A^2 (P + mg / A)}{2\gamma V m}}$

(b) $\omega = \sqrt{\frac{2\gamma A^2 (P + mg / A)}{V m}}$

(c) $\omega = \sqrt{\frac{A^2 (P + mg / A)}{\gamma V m}}$

(d) $\omega = \sqrt{\frac{\gamma A^2 (P + mg / A)}{V m}}$

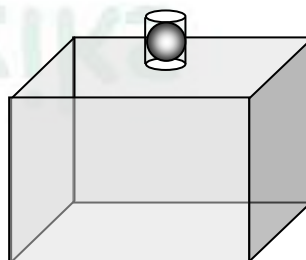

- Q11. A paper has been cut into the shape given in figure (ABCD is a square and the two hexagonal flaps are regular) and placed on the table. The square base lies flat on the table. The hexagonal flaps are then folded upwards along the edges AB and AD such that edges AE and AF of the two hexagons coincide. What is the minimum angle (in degrees) made by the edge AE (or AF) with the surface of the table?

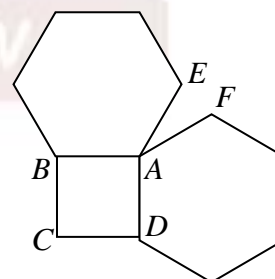

- (a) 120 (b) 85 (c) 60 (d) 45

Q12. Which one of the following sets correctly represents the Hamilton's equations of motion

obtained from the Lagrangian $L = \frac{1}{2}m\dot{x}\dot{y} - \frac{1}{2}m\omega^2xy$

- (a) $m\dot{x} = 2p_y, \dot{p}_x = -\frac{1}{2}m\omega^2y, m\dot{y} = 2p_x, \dot{p}_y = -\frac{1}{2}m\omega^2x$
- (b) $m\dot{x} = 2p_y, \dot{p}_x = -\frac{1}{2}m\omega^2x, m\dot{y} = 2p_x, \dot{p}_y = -\frac{1}{2}m\omega^2y$
- (c) $m\dot{x} = p_x, \dot{p}_x = -m\omega^2x, m\dot{y} = p_y, \dot{p}_y = -m\omega^2y$
- (d) $m\dot{x} = p_y, \dot{p}_x = -m\omega^2y, m\dot{y} = p_x, \dot{p}_y = -m\omega^2x$

Q13. A particle is in the n th energy eigenstate of an infinite one-dimensional potential well between $x=0$ and $x=L$. Let P be the probability of finding the particle between $x=0$ and $x=1/3$. In the limit $n \rightarrow \infty$, the value of P is

- (a) $1/9$ (b) $2/3$ (c) $1/3$ (d) $1/\sqrt{3}$

Q14. Two equal masses A and B are connected to a fixed support at the origin by two identical springs with spring constant K and the same unstretched length L . They are also connected to each other by a spring with spring constant K' and unstretched length $\sqrt{2}L$. The equilibrium position, with all springs unstretched, is shown in the figure. If A is constrained to move only along the x axis and B is constrained to move only along the y axis, then the angular frequencies ω_1, ω_2 of the normal modes are

- (a) $\omega_1 = \sqrt{\frac{K}{m}}, \omega_2 = \sqrt{\frac{K+K'}{m}}$
- (b) $\omega_1 = \sqrt{\frac{K}{m}}, \omega_2 = \sqrt{\frac{2K'}{m}}$
- (c) $\omega_1 = \sqrt{\frac{2K}{m}}, \omega_2 = \sqrt{\frac{K+K'}{m}}$
- (d) $\omega_1 = \sqrt{\frac{K}{m}}, \omega_2 = \sqrt{\frac{K+2K'}{m}}$

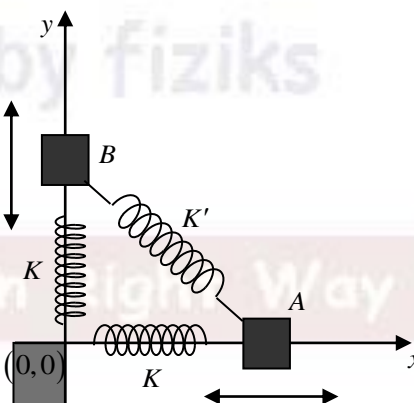

Q15. Consider the infinite series $\exp\left[\left(x + \frac{x^3}{3} + \dots\right)^2 - \left(\frac{x^2}{2} + \frac{x^4}{4} + \dots\right)^2\right]$.

Which one of the following represents this series?

- (a) $(1+x)^{\ln(1-x)}$ (b) $\exp\left[\sin^2 x - (\cos x - 1)^2\right]$
- (c) $\exp(xe^x)$ (d) $(1-x)^{-\ln(1+x)}$

Part-C: 2-Mark Numerical Questions

Q1. Consider a real tensor T_{ijk} with $i, j, k = 1, \dots, 5$. It has the following properties:

$$T_{ijk} = T_{jik} = T_{ikj}, \quad \sum_i T_{iik} = 0$$

What is the number of independent real components of this tensor?

Q2. A circular ring of radius R with total charge Q_{ring} has uniform linear charge density. It rotates about an axis passing through its centre and perpendicular to its plane with a constant angular speed ω . The magnetic field at the centre is found to be B_0 . Another thin circular disk of the same radius R has a constant surface charge density with a total charge Q_{disk} . This disk too rotates about the same axis as the ring with the same constant angular speed ω . The magnetic field at the centre in this case is found to be $10^{-3} B_0$. What is the value of Q_{ring} / Q_{disk} ?

Q3. Five distinguishable particles are distributed in energy levels E_1 and E_2 with degeneracy of 2 and 3 respectively. Find the number of microstates with three particles in energy level E_1 and two particles in E_2 .

Q4. The uncertainty Δx in the position of a particle with mass m in the ground state of a harmonic oscillator is $2\hbar / mc$. What is the energy (in units of $10^{-4} mc^2$) required to excite the system to the first excited state?

Q5. Assume the earth to be an uniform sphere of radius 6400 km and having a uniform electric permittivity of 8.85×10^{-12} Farad/m. What would be the self capacitance (in micro-Farads) of the earth? Round off your answer to the nearest integer.

Q6. An aircraft flies over the North Pole at a constant speed of 900 Km/hr . A small bob is hanging freely from the ceiling of the aircraft. What is the angle (in micro-radians) it makes with the Earth's radial direction? (Take the acceleration due to gravity to be 9.81 m/s^2).

Q7. Evaluate the integral to the nearest integer

$$I = 100 \int_0^{\infty} \frac{dt}{t} [\exp(-t) - \exp(-10t)]$$

- Q8. A thin tube of length 1080 mm and uniform cross-section is sealed at both ends, and placed horizontally on a table. At the exact center of the tube is a mercury (Hg) pellet of length 180 mm . The pressure of the air on both sides of the mercury pellet is P_0 . When the tube is held at an angle of 60 degrees with the vertical, the length of the air column above and below the Hg become 480 mm and 420 mm , respectively. Assuming the temperature of the system to be constant, calculate the pressure P_0 in mm of Hg .

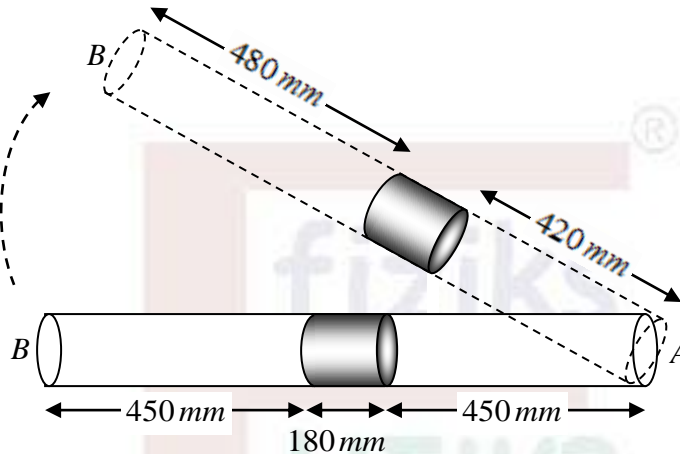

- Q9. In the following transistor circuit $R_1 = 0.5\text{ k}\Omega$, $R_E = R_C = 2\text{ k}\Omega$, $R_B = 200\text{ k}\Omega$, $\beta = \frac{I_C}{I_B} = 100$, $V_{CC} = 10\text{ V}$, $V_{BE} = 0.7\text{ V}$. Determine the V_{CE} in mV .

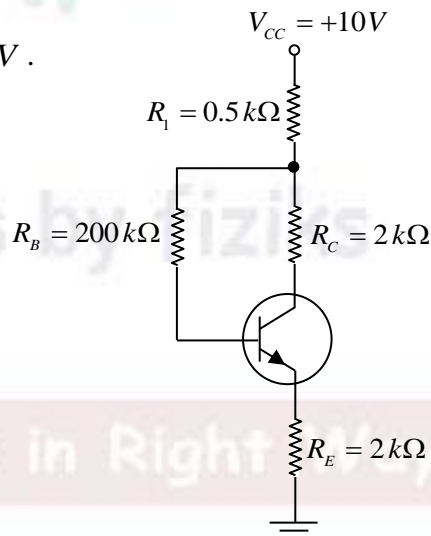

- Q10. A binary star system consists of two stars with same mass M revolving about a common centre of mass in a circular orbit with velocities much smaller than the speed of light, $c = 3.0 \times 10^8\text{ m/s}$. The axis of the plane of rotation is perpendicular to our line of sight. The wavelength of a particular spectral line from one of the stars is observed to change with a period of 2.40×10^5 seconds. If the ratio of maximum to minimum wavelength of the line is 1.0022 , the distance between the stars (in 10^9 m) to the nearest integer is

Learn Physics in Right Way

Courses for NET-JRF, IIT-JAM, GATE, JEST, TIFR & Other M.Sc. Entrances



Offline Classes



Online Live Classes



Online Pre-recorded Classes

Study Material

Online Test Series

Interview Guidance

Our Teaching Methodologies

- Well Planned Course Structure
- Develop Conceptual Clarity
- Learn Problem Solving Techniques
- Build Speed and Accuracy
- Individual Mentoring
- One on One Discussion
- Instant Doubts Clearing
- Steps to Achieve Competence [QIP]
- Better Time Management
- Performance Analysis
- Student Learning Outcome

Be Part of Disciplined Learning



011-26865455, +9871145498

Head Office: House No. 40-D, Ground Floor, Jia Sarai
Near IIT-Delhi, Hauz Khas, New Delhi-110016