

Solution

GATE Full Length Test -01

GENERAL APTITUDE

**Ans. 1: (c)**

**Solution:** Since a large number of students were protesting, we can easily conclude that some students were definitely involved in the protest. Other statements do not directly follow from the given statement.

**Ans. 2: (a)**

**Solution:**  $x^3 + 1 = 0 \Rightarrow (x+1)(x^2 - x + 1) = 0 \Rightarrow x = -1$

The other two roots are complex conjugates

Now,  $|3\alpha| - |-\alpha| = 3|-1| - |1| = 3 - 1 = 2$

**Ans. 3: (d)**

**Solution:** Due to the wording of sentence, past participle form of verb deteriorate should be used. The past participle of deteriorate is deteriorating.

**Ans. 4: (c)**

**Solution:** From the second statement we can arrange the marks as

$$\begin{matrix} & & & E & & & \\ \bullet & \bullet & \bullet & \bullet & \bullet & \bullet & \bullet \end{matrix}$$

From the fourth statement we can arrange the marks as

$$\begin{matrix} & & & E & & A & \\ \bullet & \bullet & \bullet & \bullet & \bullet & \bullet & \bullet \end{matrix}$$

From the first and fifth statements  $D, B, C$  and  $F$  have not scored the highest marks.

Hence marks scored by  $G$  is highest.

**Ans. 5: (d)**

**Solution:** Suppose the unit digit of the number is 2

$$\begin{matrix} \underline{1} & \underline{3} & \underline{2} \\ 1 \text{ way} & 7 \text{ ways} & 1 \text{ way} & 6 \text{ ways} & 1 \text{ way} \end{matrix}$$

Then the number of numbers formed

$$= 7 \times 6 = 42$$

If the unit digit of the number is not 2, then there are two possibilities

(a) The leftmost digit is not 2:

$$\begin{matrix} \underline{3} \\ \underline{\quad} & \underline{\quad} & \underline{\quad} & \underline{\quad} & \underline{\quad} \\ 7 \text{ ways} & 7 \text{ ways} & 6 \text{ ways} & 7 \text{ ways} \end{matrix}$$

In this case the number of numbers formed is  $7 \times 7 \times 6 \times 7 = 2058$

(b) The leftmost digit is 2:

$$\begin{matrix} \underline{2} & \underline{3} \\ \underline{\quad} & \underline{\quad} & \underline{\quad} & \underline{\quad} & \underline{\quad} \\ 1 \text{ way} & 7 \text{ ways} & 6 \text{ ways} & 8 \text{ ways} \end{matrix}$$

In this case the number of numbers formed  $= 8 \times 6 \times 7 = 336$

Hence total number of five digit numbers formed under the given conditions

$$= 42 + 2058 + 336 = 2436$$

**Ans. 6: (c)**

**Solution:** The correct phrasal verb is to 'look after'. It means caring for.

**Ans. 7: (b)**

**Solution:** If  $r$  and  $h$  are the box radius and height of cylinder then the base radius and height of cone are  $r$  and  $2h$  respectively.

$$\text{Volume of cylinder} = \pi r^2 h$$

$$\text{Volume of cone} = \frac{1}{3} \pi r^2 (2h) = \frac{2}{3} \pi r^2 h$$

$$\text{Volume of cylinder} - \text{Volume of cone} = \pi r^2 h - \frac{2}{3} \pi r^2 h = \frac{1}{3} \pi r^2 h$$

$$\text{Hence volume of cone is less than the volume of cylinder by } \frac{\frac{1}{3} \pi r^2 h}{\pi r^2 h} \times 100 = \frac{100}{3} \%$$

**Ans. 8: (d)**

**Solution:** From the fact that there is severe debate in the academic circle about corruption, we can conclude that for academic persons corruption is a topic of discussion.

**Ans. 9: (c)**

**Solution:** Both 'muse' and 'ponder' means 'to think carefully'.

**Ans. 10: (d)**

**Solution:** If we arrange the given persons according to their weights then we have the following two possibilities

$$X, Z = A, Y \text{ or } Z = A, X, Y$$

Hence we cannot conclude that  $X$  is heavier than  $A$  neither can we conclude that  $X$  is heavier than  $Z$ . Similarly, we cannot conclude that  $A$  is heavier than  $X$ . In both possibilities we see that  $A$  is heavier than  $Y$ .

**Ans. 11: (a)**

$$\text{Solution: } V(x) = x^2 - x^4, \quad \frac{\partial V}{\partial x} = 2x - 4x^3 = 0 \Rightarrow 2x[1 - 2x^2] = 0 \Rightarrow x = \pm \frac{1}{\sqrt{2}}, 0$$

$$\frac{\partial^2 V}{dx^2} = 2 - 12x^2$$

$$\text{For stable point } \frac{\partial V}{\partial x} = 0 \text{ and } \frac{\partial^2 V}{\partial x^2} > 0$$

$$\left. \frac{\partial^2 V}{dx^2} \right|_{x=\pm \frac{1}{\sqrt{2}}} = 2 - 12 \times \frac{1}{2} = -4 < 0 \text{ and } \left. \frac{\partial^2 V}{dx^2} \right|_{x=0} = 2 > 0$$

$$\omega = \sqrt{\frac{\left. \frac{\partial^2 V}{\partial x^2} \right|_{x=0}}{m}} = \sqrt{2} \Rightarrow \frac{2\pi}{T} = \sqrt{2} \Rightarrow T = \sqrt{2}\pi$$

Ans. 12: (b)

**Solution:** So anyway, the field, at a point anywhere along the axis of the loop is

$$\vec{B} = \frac{\mu_0 I}{2} \frac{b^2}{(x^2 + b^2)^{3/2}}$$

At a point far, far, away,  $x \gg b$ , and thus  $\vec{B} \approx \frac{\mu_0 I b^2}{2 x^3} = \frac{\mu_0 I b^2}{2 x^3}$

Set  $x = c$ , where  $c$  is the fixed coordinate of that point, to get that the field is proportional to  $Ib^2$ , as in choice (b).

Ans. 13: (a)

**Solution:**  $f(z) = \sin \pi z^2 + \cos \pi z^2$

and  $z = 1, 2$  are simple pole lies inside  $C$

$$\oint_C \frac{f(z)}{z-2} dz - \oint_C \frac{f(z)}{z-1} dz$$

$$f(2)2\pi i - f(1)2\pi i = [\sin \pi 4 + \cos \pi 4 - \sin \pi - \cos \pi] 2\pi i$$

$$= 2\pi i [0 + 1 - 0 + 1] = 4\pi i$$

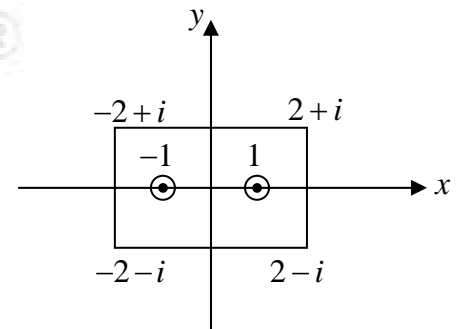

Ans. 14: (d)

**Solution:**  $\eta^2 + \xi^2 = R^2$  where  $R = \left( \frac{2mV_0 a^2}{\hbar^2} \right)^{1/2}$

Condition that there is not any odd energy eigen state is  $R < \frac{\pi}{2}$ .

$$\text{So } V_0 < \frac{\hbar^2 \pi^2}{8ma^2}$$

Ans. 15: (c)

**Solution:** We use  $dU = C_v dT + \frac{a}{V^2} dV$

$$\text{Now, } dQ = C_v dT + \frac{RT}{V-b} dV$$

$$\text{So along constant } P, C_p = C_v + \frac{RT}{V-b} \left( \frac{\partial V}{\partial T} \right)_P$$

$$\text{On differentiating } T \text{ at constant } P, P = \frac{RT}{(V-b)} - \frac{a}{V^2}$$

$$0 = \left( -\frac{RT}{(V-b)^2} + \frac{2a}{V^3} \right) \left( \frac{\partial V}{\partial T} \right)_p + \frac{R}{V-b} \quad \left( \frac{\partial V}{\partial T} \right)_p = \frac{\frac{R}{V-b}}{\left( \frac{RT}{(V-b)^2} - \frac{2a}{V^3} \right)}$$

$$\text{or, } T \left( \frac{\partial V}{\partial T} \right)_p = \frac{\frac{RT}{V-b}}{\frac{RT}{(V-b)^2} - \frac{2a}{V^3}} = \frac{V-b}{1 - \frac{2a(V-b)^2}{RTV^3}} \text{ and } C_p - C_v = \frac{R}{1 - \frac{2a(V-b)^2}{RTV^3}}$$

**Ans. 16: (b)**

**Solution:**  $L = \tau t = I\omega \Rightarrow \omega = \frac{\tau t}{I} = 0.3 \text{ sec}^{-1}$

**Ans. 17: (a)**

**Solution:** In *KCl* crystal only even (*hkl*) planes are present. All odd (*hkl*) and mixed (*hkl*) are absent.

Thus, the correct option is (a).

**Ans. 18: (a)**

**Solution:** We know that  $\cos 2t = 2\cos^2 t - 1$

$$\cos^2 t = \frac{1}{2} [\cos 2t + 1]$$

$$L(\cos^2 t) = L \left[ \frac{1}{2} (\cos 2t + 1) \right] = \frac{1}{2} [L(\cos 2t) + L(1)]$$

$$= \frac{1}{2} \left[ \frac{s}{s^2 + (2)^2} + \frac{1}{s} \right] = \frac{1}{2} \left[ \frac{s}{s^2 + 4} + \frac{1}{s} \right]$$

**Ans. 19: (d)**

**Solution:**  $Z = 29: (1s_{1/2})^2 (1p_{3/2})^4 (1p_{1/2})^2 (1d_{5/2})^6 (2s_{1/2})^2 (1d_{3/2})^6 (1f_{7/2})^4$

$\therefore I = \frac{7}{2}$  and  $p = (-1)^l = (-1)^3 = -ve$

$\therefore \text{spin} = \left( \frac{7}{2} \right)^-$

**Ans. 20: (c)**

**Solution:** Recall Faraday Law,  $\varepsilon = -\frac{d\Phi}{dt}$ , where  $\Phi = \vec{B} \cdot \vec{A} = B \cos(\omega t) \pi R^2$ ,

Thus  $\varepsilon_0 \sin \omega t = -[-\omega B \sin(\omega t) \pi R^2] \Rightarrow \omega = \frac{\varepsilon_0}{B \pi R^2}$

Ans. 21: (b)

**Solution:** No parity changes in transition from  $\left(\frac{9}{2}\right)^+ \rightarrow \left(\frac{7}{2}\right)^+$

$$\text{Now } I_i = \frac{9}{2} : I_f = \frac{7}{2}$$

$$\Delta I = 1, 2, 3, \dots, 8$$

The most probable transition is  $\Delta J = 1$  and without change in parity. The multipole radiations is  $M1$ .

Ans. 22: (b)

**Solution:**  $\langle r^2 - xy - z^2 \rangle = \langle r^2 \rangle - \langle x \rangle \langle y \rangle - \langle z^2 \rangle = 3a_0^2 - 0 - a_0^2 = 2a_0^2$

Ans. 23: (d)

**Solution:**

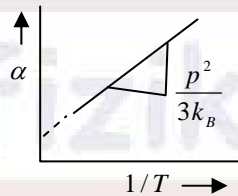

In graph between  $\alpha$  and  $1/T$ , the slope represents the electric dipole moment. Higher the slope means higher the electric dipole moment.

Therefore,  $(Slope)_D > (Slope)_B > (Slope)_A > (Slope)_C$

Thus,  $p_D > p_B > p_A > p_C$

Correct option is (d)

Ans. 24: (d)

**Solution:** For electric dipole transition,  $L = 2$  and parity remain unchanged

Thus,  $0^+ \rightarrow 2^+$  is through  $E2$  transition.

Ans. 25: (c)

**Solution:**  $F = -k_B T \ln Z$  Since,  $P = -\frac{\partial F}{\partial V} \Rightarrow P = K_B T \left( \frac{\partial \ln z}{\partial V} \right)_T = \frac{\pi^2 (k_B T)^4}{45 \hbar^3 C^3}$

Ans. 26: (c)

**Solution:**  $f(x) = \frac{1}{2\pi} \int_{-\infty}^{\infty} \frac{2}{1+k^2} e^{-ikx} dk$

$$= \frac{1}{2\pi} 2 \int_{-\infty}^{\infty} \frac{e^{-ikx}}{(k+i)(k-i)} dk$$

$$f(z) = \frac{e^{-iix}}{2i} \quad \text{Residue } k = i$$

$$= \frac{e^x}{2i} \quad \text{for } R > 0$$

$$f(x) = \frac{1}{2\pi} 2 \cdot 2\pi i \cdot \frac{e^x}{2i} = e^x$$

$$f(x) = e^{-x} \quad \text{for } R < 0$$

$$f(x) = e^{-|x|}$$

Ans. 27: (a)

**Solution:** Voltage across the capacitor at 1 sec after the circuit is closed

$$v_c = V(1 - e^{-t/RC}) = 110 \left[ 1 - e^{-\frac{1}{(2 \times 10^3)(10^3 \times 10^{-6})}} \right] = 110 [1 - e^{-1/2}] = 110 \times 0.393 = 43.2V$$

Ans.28: (a), (b) and (c)

**Solution:**

Here V is a function of only r and not  $\theta$ , and  $\phi$ . Then Laplace's equation

$$\nabla^2 V = \frac{1}{r^2} \frac{\partial}{\partial r} \left( r^2 \frac{\partial V}{\partial r} \right) = 0$$

Integrating twice, we get  $V = -\frac{A}{r} + B$

The boundary conditions are

$$V = 0 \text{ V at } r = 10 \text{ cm} = 0.1 \text{ m}$$

$$V = 10 \text{ V at } r = 20 \text{ cm} = 0.2 \text{ m}$$

$$\text{i.e., } \frac{-A}{0.1} + B = 0 \text{ and } \frac{-A}{0.2} + B = 10$$

$$\therefore A = 2.0 \text{ Volt-m and } B = 20 \text{ V}$$

$$\Rightarrow V = -\frac{2}{r} + 20 \text{ Volts}$$

$$\Rightarrow \vec{E} = -\vec{\nabla}V = -\frac{\partial V}{\partial r} \hat{r} = -\frac{2}{r^2} \hat{r} \text{ V/m}$$

$$\Rightarrow \vec{D} = \epsilon_0 \vec{E} = -\frac{2\epsilon_0}{r^2} \hat{r} \text{ C/m}^2 = -\frac{2}{r^2} (8.854 \times 10^{-12}) \hat{r} \text{ C/m}^2 \Rightarrow \vec{D} = -\frac{17.708}{r^2} \hat{r} \text{ pC/m}^2$$

Ans. 29: (a), (b), (c)

Ans. 30: (a), (b), (c)

**Solution:**

$$F = (A \oplus B) \odot (A \odot B) \odot C = \{(A \oplus B)(A \odot B) + (A \odot B)(A \oplus B)\} \odot C$$

$$\Rightarrow F = \{(A \oplus B)(A \odot B)\} \odot C = 0 \odot C = 0C + 1\bar{C} = \bar{C}$$

Ans. 31 (d)

**Solution:**

$\psi(x) = Ax^2 e^{-\alpha x^2}$  is finite, single valued and continuous.

It's derivative,  $\frac{d\psi}{dx} = 2Ax e^{-\alpha x^2} - 2A\alpha x^3 e^{-\alpha x^2}$  is also finite, single valued and continuous.

The function is square integrable

$$\int_{-\infty}^{+\infty} (\psi)^2 dx = |A|^2 \int_{-\infty}^{+\infty} e^{-2\alpha x^2} x^4 dx = \frac{|A|^2 \sqrt{\frac{5}{2}}}{2\alpha^{5/2}} = \text{finite}$$

Ans. 32: (a), (b) & (d)

**Solution:**

In KCl only even (hkl) are present in the XRD spectrum. All other planes are absent.

Therefore, the planes (200), (220) and (222) are absent while (111) is absent

Ans. 33: 2.5

**Solution:**  $\left(\frac{\partial G}{\partial T}\right)_P = -S = -Nk_B \ln\left(\frac{aVE^{3/2}}{N^{5/2}}\right) \therefore S = Nk_B \ln\left(\frac{aVE^{3/2}}{N^{5/2}}\right)$

$$\Rightarrow G = -Nk_B T \ln\left(\frac{aVE^{3/2}}{N^{5/2}}\right) + \ln A$$

$$\Rightarrow \mu = \left(\frac{\partial G}{\partial N}\right) = -\left[k_B T \ln\left(\frac{aVE^{3/2}}{N^{5/2}}\right) + Nk_B T \frac{N^{5/2}}{aVE^{3/2}} \cdot \frac{(-5/2)}{N^{7/2}} aVE^{3/2}\right] = -k_B T \left[\ln\left(\frac{aVE^{3/2}}{N^{5/2}}\right) - \frac{5}{2}\right]$$

Ans. 34: 0.48

**Solution:**  $T_F = \frac{E_F}{k_B}$  where  $E_F = \frac{\hbar^2}{2m} (3\pi^2 n)^{2/3}$

$$\therefore \frac{(T_F)_A}{(T_F)_B} = \frac{(E_F)_A}{(E_F)_B} = \left(\frac{n_A}{n_B}\right)^{2/3} = \left(\frac{1}{3}\right)^{1/3} = 0.48$$

Ans. 35: 2.44

**Solution:** Spin  $s = \frac{1}{2}$  means particles are fermions and it will obey Pauli Exclusion Principle.

Degeneracy,  $g = 2s + 1 \Rightarrow g = 2$  means in every state maximum 2 identical particle can be adjusted. If we have three fermions, then in ground state two fermions will be adjusted and one fermion in next higher level will be adjusted. Thus, the energy of the lowest energy state of the

system is  $2 \times \frac{\pi^2 \hbar^2}{2ma^2} + \frac{4\pi^2 \hbar^2}{2ma^2} = \frac{6\pi^2 \hbar^2}{2ma^2} = \frac{3\pi^2 \hbar^2}{ma^2} = \frac{6\pi^2 \hbar^2}{2ma^2} \Rightarrow \alpha = \sqrt{6} = 2.44$

**Ans. 36: (a)**

**Solution:**  $H = \frac{xp^2}{2m} - \frac{1}{2}kx$

$$\frac{\partial H}{\partial p} = \dot{x} \Rightarrow \frac{xp}{m} = \dot{x} \quad p = \frac{m\dot{x}}{x}$$

$$L = \dot{x}p - H \Rightarrow L = \dot{x}p - \frac{xp^2}{2m} + \frac{1}{2}kx = \frac{m\dot{x}^2}{x} - \frac{m\dot{x}^2}{2x} + \frac{1}{2}kx = \frac{m\dot{x}^2}{2x} + \frac{1}{2}kx$$

Euler Lagrange's equation is given by

$$\frac{d}{dt} \left( \frac{\partial L}{\partial \dot{x}} \right) - \frac{\partial L}{\partial x} = 0$$

$$\frac{m\ddot{x}}{x} - \frac{m\dot{x}\dot{x}}{x^2} - \frac{1}{2}k = 0$$

$$2xm\ddot{x} - m\dot{x}^2 - kx^2 = 0$$

**Ans. 37: (d)**

**Solution:**  $\oint \vec{E} \cdot d\vec{A} = \frac{Q_{enc}}{\epsilon_0}$

For  $r < R$ ;  $E \times 4\pi r^2 = \frac{1}{\epsilon_0} \left( \rho \times \frac{4}{3} \pi r^3 \right) \Rightarrow E = \frac{\rho r}{3\epsilon_0}$

For  $r > R$ ;  $E \times 4\pi r^2 = \frac{1}{\epsilon_0} \left( \rho \times \frac{4}{3} \pi R^3 \right) \Rightarrow E = \frac{\rho R^3}{3\epsilon_0 r^2}$

For  $r < R$ ;  $V(r) = -\int_{\infty}^r \vec{E} \cdot d\vec{l} = -\int_{\infty}^R \vec{E}_2 \cdot d\vec{l} - \int_R^r \vec{E}_1 \cdot d\vec{l}$

$$V(r) = -\int_{\infty}^R \frac{\rho R^3}{3\epsilon_0 r^2} dr - \int_R^r \frac{\rho r}{3\epsilon_0} dr = \frac{\rho R^2}{3\epsilon_0} - \frac{\rho}{3\epsilon_0} \left( \frac{r^2 - R^2}{2} \right)$$

$$\Rightarrow V(0) = \frac{\rho R^2}{3\epsilon_0} + \frac{\rho R^2}{6\epsilon_0} = \frac{\rho R^2}{2\epsilon_0} \quad \text{and} \quad V(R) = \frac{\rho R^2}{3\epsilon_0}$$

$$\Rightarrow V(R) - V(0) = \frac{\rho R^2}{3\epsilon_0} - \frac{\rho R^2}{2\epsilon_0} = -\frac{\rho R^2}{6\epsilon_0}$$

$$\Delta PE = (V_{sur} - V_{cent}) q = -\frac{q}{6\epsilon_0} \rho R^2$$

**Ans. 38: (b)**

**Solution:** We can use Bohr Sommerfield theory

$$V(x) = cx^8$$

$$\oint P dx = nh \Rightarrow 4 \int_0^{\left(\frac{E}{C}\right)^{1/8}} \sqrt{2m(E - cx^8)} dx = nh \Rightarrow \sqrt{2mE} \left(\frac{E}{C}\right)^{1/8} \int_0^t \sqrt{1-t^8} dt = nh$$

$$E^{1/2+1/8} \propto n = E^{\frac{4+1}{8}} \propto n \Rightarrow E \propto n^{8/5}$$

therefore correct option is (b)



Ans. 39: (c)

**Solution:** The coefficient of thermal conducting is continuous at the critical temperature.

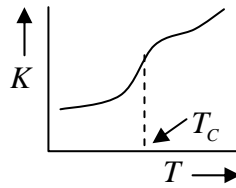

Ans. 40: (a)

**Solution:**  $V(x, y) = x + 2y$

$$H = \frac{p_x^2}{2m} + \frac{p_y^2}{2m} + x + 2y$$

$$(1) \frac{d(p_y - 2p_x)}{dt} = [p_y - 2p_x, H] + \frac{\partial}{\partial t}(p_y - 2p_x)$$

$$= [p_y - 2p_x, H] = [p_y - 2p_x, x + 2y] = [p_y, 2y] - [2p_x, x] = -2 + 2 = 0$$

$$(2) \frac{d(p_x - 2p_y)}{dt} = [p_x - 2p_y, H] + \frac{\partial}{\partial t}(p_x - 2p_y)$$

$$= [p_x - 2p_y, H] = [p_x - 2p_y, x + 2y] = [p_x, x] - [2p_y, 2y] = -1 + 4 = 3 \neq 0$$

Ans. 41: (d)

**Solution:**

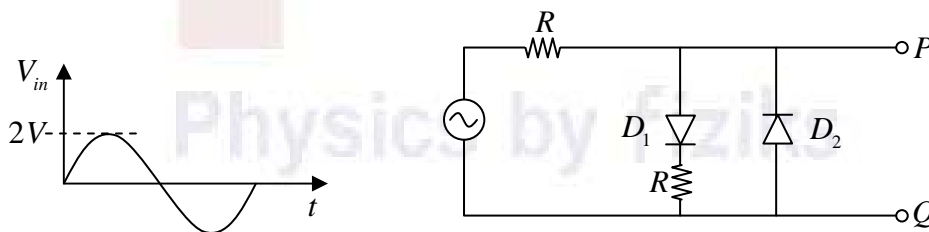

During positive half cycle  $D_1$  is forward bias, when input is less positive than  $+0.7V$ , diode is OFF and output is equal to input. When input is more positive than  $+0.7V$ ,  $D_1$  is ON and output is  $(0.7 + IR)V$ .

During negative half cycle  $D_2$  is reverse biased, when input is less negative than  $-0.7V$ , diode is OFF and output is equal to input. When input is more negative than  $-0.7V$ ,  $D_2$  is ON and output is  $-0.7V$ .

Ans. 42: (b)

**Solution:** Ground state wave function is given by  $\psi(x_1, x_2) = \sqrt{\frac{2}{a}} \sin \frac{\pi x_1}{a} \sqrt{\frac{2}{a}} \sin \frac{\pi x_2}{a}$

$$\int_0^a \psi^*(x_1, x_2) V(x_1, x_2) \psi(x_1, x_2) dx_1 dx_2$$

$$-V_0 \cdot a \cdot \left(\frac{2}{a}\right)^2 \int_0^a \sin^2\left(\frac{\pi x_1}{a}\right) \cdot \sin^2\left(\frac{\pi x_2}{a}\right) \delta(x_1 - x_2) dx_1 dx_2$$

$$-V_0 \cdot a \cdot \left(\frac{2}{a}\right)^2 \int_0^a \sin^4\left(\frac{\pi x_2}{a}\right) dx_2 \quad \text{put } \frac{\pi x_2}{a} = t \Rightarrow dx_2 = \frac{a}{\pi} dt$$

$$-V_0 a \left(\frac{2}{a}\right)^2 \int_0^a \sin^4\left(\frac{\pi x_2}{a}\right) dx_2 \Rightarrow -V_0 a \frac{4}{a^2} \frac{a}{\pi} \int_0^\pi \sin^4 t dt \Rightarrow -\frac{4}{\pi} V_0 \int_0^\pi \sin^4 t dt \Rightarrow -\frac{4V_0}{\pi} \frac{3\pi}{8} = -\frac{3V_0}{2}$$

$$2 \times \frac{\pi^2 \hbar^2}{2ma^2} - \frac{3}{2} V_0 \Rightarrow \frac{\pi^2 \hbar^2}{ma^2} - \frac{3}{2} V_0$$

Ans. 43: (d)

**Solution:** Equating the centripetal force with the Lorentz Force,  $mv^2/R = qvB$ . The radius of curvature used in the centripetal force equation is given by  $R^2 = l^2 + (R - s)^2$ ,

$$\Rightarrow R^2 = l^2 + (R - s)^2 = l^2 + R^2 + s^2 - 2Rs \approx l^2 + R^2 - 2Rs \quad \because s \ll l$$

$$\Rightarrow l^2 = 2Rs \Rightarrow R = l^2 / (2s).$$

$$\text{Now } mv/R = qB \Rightarrow 2smv/l^2 = qB \Rightarrow p = mv = qBl^2 / 2s,$$

Ans. 44: (b)

$$\text{Solution: } \hat{A} = \lambda \vec{s} \cdot \vec{\beta}, \quad \vec{B} = \frac{B}{\sqrt{2}} (\hat{x} + \hat{y})$$

$$\hat{A} = \lambda \frac{\hbar}{2} [\sigma_x B_x + \sigma_y B_y]$$

$$\hat{A} = \frac{\lambda \hbar}{2} \left[ \begin{pmatrix} 0 & 1 \\ 1 & 0 \end{pmatrix} \frac{B}{\sqrt{2}} + \begin{pmatrix} 0 & -i \\ i & 0 \end{pmatrix} \frac{B}{\sqrt{2}} \right] \Rightarrow \hat{A} = \frac{\lambda \hbar B}{2\sqrt{2}} \begin{bmatrix} 0 & 1-i \\ 1+i & 0 \end{bmatrix}$$

$$|A - \lambda'I| = 0 \Rightarrow \frac{\lambda \hbar B}{2\sqrt{2}} \begin{vmatrix} -\lambda & 1-i \\ 1+i & -\lambda \end{vmatrix} = 0 \Rightarrow \lambda' = \pm \frac{\lambda \hbar B}{2}$$

Ans. 45: (d)

Solution:

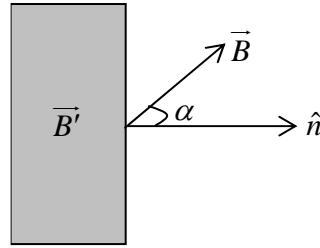

$$B_2^\perp = B_1^\perp \Rightarrow B'_n = B \cos \alpha$$

$$H_2^\parallel = H_1^\parallel$$

$$\Rightarrow H_2^\parallel = \frac{B_1^\parallel}{\mu_0} = \frac{B \sin \alpha}{\mu_0} \Rightarrow B'_t = \mu \mu_0 \frac{B \sin \alpha}{\mu_0} = \mu B \sin \alpha$$

$$\text{Thus, } B' = \sqrt{(B'_n)^2 + (B'_t)^2} = \sqrt{(B \cos \alpha)^2 + (\mu B \sin \alpha)^2} \Rightarrow B' = B \sqrt{\cos^2 \alpha + \mu^2 \sin^2 \alpha}$$

$$\Rightarrow B' = B \sqrt{\cos^2 \alpha + \mu^2 (1 - \cos^2 \alpha)} \Rightarrow B' = B \sqrt{\mu^2 + (1 - \mu^2) \cos^2 \alpha}$$

Ans. 46: (d)

Solution:

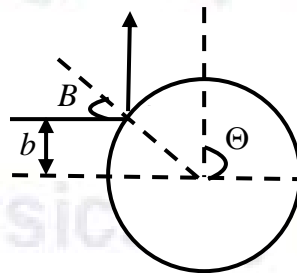

As  $m < M$ , the massive billiard ball will remain stationary during scattering. As the scattering is elastic the scattering angle  $\Theta$  is related to the angle of incidence by

$$\Theta = \pi - 2\theta$$

where  $\theta$  is given by

$$(a + r) \sin \theta = b.$$

The differential scattering cross section is

$$\frac{d\sigma}{d\Omega} = \frac{b}{\sin \theta} \frac{db}{d\theta} = \frac{1}{4} (a + r)^2.$$

As  $\frac{d\sigma}{d\Omega}$  is isotropic, the total cross section is

$$\sigma_t = 4\pi \frac{d\sigma}{d\Omega} = \pi (2R + R)^2 = 9\pi R^2.$$

Ans. 47: (a)

**Solution:** Let  $f(x) = a_0 + \sum_{n=1}^{\infty} (a_n \cos nx + b_n \sin nx)$

$$a_0 = \frac{1}{2\pi} \int_{-\pi}^{\pi} f(x) dx = \frac{1}{2\pi} \left[ \int_{-\pi}^0 (0) dx + \int_0^{\pi} (k) dx \right] = \frac{1}{2\pi} k\pi = \frac{k}{2}$$

$$\therefore a_n = \frac{1}{\pi} \int_{-\pi}^{\pi} f(x) \cos nxdx$$

$$\Rightarrow a_n = \frac{1}{\pi} \left[ \int_{-\pi}^0 (0) \cos nxdx + \int_0^{\pi} (k) \cos nxdx \right] \Rightarrow a_n = \frac{k}{\pi} \left\{ \frac{\sin nx}{n} \right\}_0^{\pi} = 0$$

$$\therefore b_n = \frac{1}{\pi} \int_{-\pi}^{\pi} f(x) \sin nxdx$$

$$\Rightarrow b_n = \frac{1}{\pi} \left[ \int_{-\pi}^0 (0) \sin nxdx + \int_0^{\pi} (k) \sin nxdx \right] \Rightarrow b_n = -\frac{1}{\pi} \left\{ \frac{\cos nx}{n} \right\}_0^{\pi} = -\frac{1}{\pi n} [(-1)^n - 1]$$

Thus Fourier series is  $f(x) = \frac{k}{2} + \sum_{n=1}^{\infty} \frac{1}{\pi n} [1 - (-1)^n] \sin nx$

$$f(x) = \frac{k}{2} + \frac{1}{\pi} \left[ 2 \sin x + \frac{1}{2} (0) \sin 2x + \frac{1}{3} 2 \sin 3x + \frac{1}{4} (0) \sin 4x + \frac{1}{5} 2 \sin 5x \dots \right]$$

$$f(x) = \frac{k}{2} + \frac{2}{\pi} \left[ \sin x + \frac{1}{3} \sin 3x + \frac{1}{5} \sin 5x \dots \right]$$

Ans. 48: (c)

**Solution:** (a) The normalization condition

$$(\psi(x,0), \psi(x,0)) = |A|^2 \sum_{m,n} (1/2)^{(m+n)/2} (\psi_n, \psi_m)$$

$$= |A|^2 \sum_m \left( \frac{1}{2} \right)^m = 2|A|^2 = 1$$

gives  $A = 1/\sqrt{2}$ , taking  $A$  as positive real.

The expectation value of energy is

$$\langle \psi | H | \psi \rangle = \sum_{m,n} \left( \frac{1}{2} \right)^{\frac{m+n}{2}+1} \langle \psi_n | H | \psi_m \rangle = \sum_{m,n} \left( \frac{1}{2} \right)^{\frac{m+n}{2}+1} \left( m + \frac{1}{2} \right) \hbar \omega \langle \psi_n | \psi_m \rangle$$

$$\Rightarrow \sum_{m,n} \left( \frac{1}{2} \right)^{\frac{m+n}{2}+1} \left( m + \frac{1}{2} \right) \hbar \omega \delta_{m,n}$$

$$\langle H \rangle = \sum_n \left( \frac{1}{2} \right)^{n+1} \langle \psi | H | \psi \rangle = \sum_n \left( \frac{1}{2} \right)^{n+1} \left( n + \frac{1}{2} \right) \hbar \omega$$

Noting,  $\sum_{n=0}^{\infty} \frac{1}{x^n} = \frac{x}{x-1}$ , or, by differentiation  $\sum_{n=0}^{\infty} \frac{-n}{x^{n+1}} = \frac{-1}{(x-1)^2}$

we have,  $\sum_{n=0}^{\infty} \frac{n}{2^{n+1}} = 1$ , and  $\langle H \rangle = 3\hbar\omega/2$ .

Ans. 49: (c)

**Solution:**  $V_o = -\frac{R_1}{R_1}V_i + \left(1 + \frac{R_1}{R_1}\right)\frac{X_C}{R + X_C}V_i \Rightarrow \frac{V_o}{V_i} = \frac{1 - RCs}{1 + RCs}$  where  $s = j\omega$ .

Thus,  $\phi = -2 \tan^{-1}(\omega RC)$ .

Minimum value of  $\phi = -\pi$  (at  $\omega \rightarrow \infty$ )

Maximum value of  $\phi = 0$  (at  $\omega = 0$ )

Ans. 50: (b)

**Solution:** The electron configuration of  $Mn^{3+}$  is  $[Ar]3d^4$ .

For,  $d^4$ :  $M_L = \begin{array}{ccccc} -2 & -1 & 0 & +1 & +2 \\ \uparrow & \uparrow & \uparrow & \uparrow & \end{array}$

$\therefore$  The highest  $S = 2$

and the highest  $L = 3$

$\therefore J = 1, 2, 3, 4, 5$

The ground state is

$${}^{2S+1}L_J = {}^5F_1$$

Ans. 51: (c)

**Solution:**

A	B	S	R	Q	Q <sup>+</sup>
0	0	1	0	0	1
0	0	1	0	1	1
0	1	0	1	0	0
0	1	0	1	1	0
1	0	0	0	0	0
1	0	0	0	1	1
1	1	1	1	0	×
1	1	1	1	1	×

$$Q^+ = \overline{A}\overline{B} + AQ = \overline{A}\overline{B} + \overline{B}Q$$

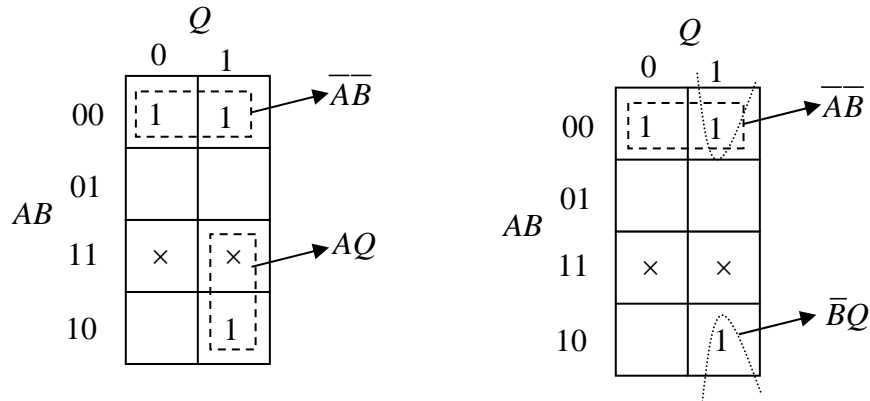

Ans. 52: (b)

Solution: (a)  $\pi^+ + p \rightarrow \Sigma^+ + K^+$

$$q: +1 + 1 \rightarrow +1 + 1: \text{conserved}$$

$$\text{spin: } 0 \frac{1}{2} \rightarrow \frac{1}{2} 0: \text{conserved}$$

$$B: +0 + 1 \rightarrow +1 + 0: \text{conserved}$$

$$I: 1 \frac{1}{2} \rightarrow 1 \frac{1}{2}: \text{conserved}$$

$$I_3: +1 + \frac{1}{2} \rightarrow +1 + \frac{1}{2}: \text{conserved}$$

$$S: 0 + 0 \rightarrow -1 + 1: \text{conserved}$$

It is allowed interaction

(b)  $\Omega^- \rightarrow \Lambda^0 + K^-$

$$q: -1 \rightarrow 0 + k^-: \text{conserved}$$

$$\text{spin: } -\frac{3}{2} \rightarrow \frac{1}{2} + 0: \text{not conserved}$$

This is not allowed interaction.

Ans. 53: (d)

Solution: If  $I_1$  and  $I_2$  are intensities of two waves then

$$\frac{I_{\max}}{I_{\min}} = \left[ \frac{\sqrt{I_1} + \sqrt{I_2}}{\sqrt{I_1} - \sqrt{I_2}} \right]^2 = \left[ \frac{\sqrt{I_1 I_2} + 1}{\sqrt{I_1 I_2} - 1} \right]^2$$

$$\text{Since, } \frac{I_1}{I_2} = \frac{16}{9} = \left( \frac{\sqrt{16/9} + 1}{\sqrt{16/9} - 1} \right)^2 = \left( \frac{4/3 + 1}{4/3 - 1} \right)^2 = \left( \frac{7/3}{1/3} \right)^2 = \left( \frac{7}{1} \right)^2 = 49:1$$

Ans. 54: (a)

$$\begin{aligned} \text{Solution: } Q_{\beta^+} &= [M(Z, A) - M(Z-1, A) - 2m_e]c^2 \\ &= [M(Z, A) - M(Z-1, A)]c^2 - 2m_e c^2 \\ &= [39.96399 - 39.962384]931.5 - 1.022 = 0.474 \text{ MeV} \end{aligned}$$

Ans. 55: (a), (b) and (c)

**Solution:**

By conservation of momentum,

$$m_1 u_1 + m_2 u_2 = m_1 U_1 + m_2 U_2 = +9 \text{ kg} - m/\text{sec}$$

$$\text{So, } U_1 = +2 \text{ m/sec}$$

The velocity of particle with respect to observer on  $S'$  frame is  $u_1' = u_1 - v = 2 \text{ m/sec}$

Similarly,  $u_2' = -5 \text{ m/sec}$

$$\text{Also, } U_1' = 0 \text{ m/sec, } U_2' = 1 \text{ m/sec}$$

Hence,  $S'$  is inertial frame of reference so,  $m_1 u_1' + m_2 u_2' = m_1 U_1' + m_2 U_2' = 1 \text{ kg} - m/\text{sec}$

Ans. 56: (a), (d)

**Solution:**

Let  $N_0$  be the number of initial number of nuclei. Then

$$n = N_0 - N_0 e^{-2\lambda} = N_0 (1 - e^{-2\lambda})$$

$$0.75n = N_0 e^{-2\lambda} - N_0 e^{-2\lambda} e^{-2\lambda} = N_0 e^{-2\lambda} (1 - e^{-2\lambda})$$

$$\frac{0.75n}{n} = \frac{N_0 e^{-2\lambda} (1 - e^{-2\lambda})}{N_0 (1 - e^{-2\lambda})} \Rightarrow e^{-2\lambda} = \frac{3}{4} \Rightarrow \lambda 0.1438 \text{ sec}^{-1} \Rightarrow \bar{T} = \frac{1}{\lambda} = 7 \text{ sec}$$

Ans. 57: (a), (c)

**Solution:**

The eccentricity of curve  $e = \sqrt{1 + \frac{2El^2}{mk^2}}$  where  $k = Gm_1 m_2$  and  $E$  is energy.

If total energy is negative then orbit can be either elliptical or circular so (a) is correct.

In two body central force problem motion is confined in a plane and angular momentum conserved so (b) is wrong.

If the total energy of the system is 0, then the orbit is a parabola one can calculate  $e = 1$  is correct

From second law of kepler  $\frac{dA}{dt} = \frac{J}{2m} \Rightarrow \frac{S}{T} = \frac{J}{2m} \Rightarrow T = \frac{2mS}{J}$  so (d) wrong.

Ans. 58: (b) and (d)

In a Carnot cycle,  $\frac{Q_2}{T_2} = \frac{Q_1}{T_1}$

$$\Delta S_{\text{universe}} = 0$$

$$\eta = 1 - \left(\frac{1}{p}\right)^{r-1}$$

and  $\Delta S_{\text{source}} = -\frac{Q_1}{T_1}$ ,  $\therefore$  source provides heat to the working substance during isothermal expansion.

Ans. 59: 0.21

$$\text{Solution: } E_1^1 = \int_0^{a/2} \psi_1^* V'(x) \psi_1 dx = \frac{2}{a} \int_0^{a/2} \sin^2\left(\frac{\pi x}{a}\right) V_0 \cos\left(\frac{\pi x}{a}\right) dx = \frac{2}{a} V_0 \left. \frac{\sin^3 \frac{\pi x}{a}}{3 \frac{\pi}{a}} \right|_0^{a/2} = \frac{2V_0}{3\pi} = 0.212V_0$$

Ans. 60: 2

$$\text{Solution: } V_{\text{eff}} = \frac{l^2}{2mr^2} + \frac{1}{4}kr^4, \text{ where } l \text{ is angular momentum.}$$

$$\text{Condition for circular orbit } \frac{\partial V_{\text{eff}}}{\partial r} = 0 \Rightarrow -\frac{l^2}{mr^3} + kr^3 = 0 \Rightarrow l^2 \propto r^6 \Rightarrow l \propto r^3.$$

$$\text{Thus } \frac{l_1}{l_2} = \left(\frac{r_1}{r_2}\right)^3 \Rightarrow \frac{r_1}{r_2} = \left(\frac{l_1}{l_2}\right)^{1/3} \Rightarrow \frac{r_1}{r_2} = 2 \text{ since } \frac{l_1}{l_2} = 8.$$

Ans. 61: 1.41

$$\text{Solution: } \left\langle \frac{1}{r^2} \right\rangle = \frac{4}{4\pi a^3} \int_0^\infty \frac{1}{r^2} r^2 e^{-\frac{2r}{a}} dr \int_0^{2\pi} \int_0^\pi \sin \theta d\theta d\phi = \frac{2}{a^2} = \left(\frac{\sqrt{2}}{a}\right)^2 \Rightarrow n = \sqrt{2}$$

Ans. 62: 6.5

$$\begin{aligned} \text{Solution: } \Delta\lambda &= \frac{\lambda^2}{c} \cdot \frac{eB}{4\pi m} = \frac{\lambda^2}{c} \cdot \mu_B \cdot \frac{B}{h} \\ &= \frac{(650 \times 10^{-9} \text{ m})^2}{3 \times 10^8 \text{ m/s}} \cdot 1.53 \times 10^{-24} \text{ J/T} \cdot \frac{2T}{6.625 \times 10^{-34} \text{ J}\cdot\text{s}} \\ &= 6.5 \times 10^{-12} \text{ m} = 6.5 \text{ pm} \end{aligned}$$

Ans. 63: 0.75

$$\begin{aligned} \text{Solution: } \text{It is given } A_0 &= a_0^2, A = a_0 \sqrt{1 - \frac{\left(\frac{c}{\sqrt{2}} \cos \frac{\pi}{4}\right)^2}{c^2}} \cdot a_0 \sqrt{1 - \frac{\left(\frac{c}{\sqrt{2}} \sin \frac{\pi}{4}\right)^2}{c^2}} \\ \Rightarrow A &= a_0^2 \left(1 - \frac{1}{4}\right) = a_0^2 \times \frac{3}{4} = \frac{3}{4} A_0 = 0.75 A_0 \end{aligned}$$

Ans. 64: 0.663

$$\text{Solution: } a = 2(r_{Na} + r_{Cl}) = 2(0.98 + 1.81) = 5.58 \text{ \AA}$$

$$\text{Packing fraction} = \frac{4\left(\frac{4\pi}{3} r_{Na}^3\right) + 4\left(\frac{4\pi}{3} r_{Cl}^3\right)}{a^3} = \frac{16\pi}{3} \left[ \frac{(0.98)^3 + (1.81)^3}{(5.58)^3} \right] = 0.663$$

Ans. 65: 0.0135

$$\begin{aligned} \text{Solution: } \left(\frac{dP}{dT}\right)_V &= \frac{L}{T(v_2 - v_1)} \Rightarrow \int_{P_1}^{P_2} dP = \frac{L}{(v_2 - v_1)} \int_{T_1}^{T_2} \frac{dT}{T} \Rightarrow P_2 - P_1 = \frac{L}{(v_2 - v_1)} \ln \frac{T_2}{T_1} \\ \Rightarrow P_2 &= P_1 + \frac{L}{(v_2 - v_1)} \ln \frac{T_2}{T_1} = 0.0135 \times 10^5 \text{ Pa} \end{aligned}$$